

## Pressure Sensor 4117

*Pressure Sensor 4117 is a compact fully integrated sensor for measuring the pressure level and the water temperature. The sensor is designed to be mounted on the AADI SEAGUARD® using AiCaP CANbus or as stand alone sensor using RS-232. The sensor is easily integrated in other measurement systems with third party data loggers.*

## Features Pressure Sensor 4117 :

- Smart sensor technology - plug and play
- Calibration coefficients are stored in the sensor
- Low maintenance needs
- Low current drain
- Depth rating of 6000 meters
- Direct readout of engineering data
- Output parameters: Pressure, Temperature
- Selectable interval from 1 second to 255 minutes
- Rugged and robust with low maintenance needs
- Use with AADI SEAGUARD® Platform
- Use as stand-alone sensor
- Output formats: AiCaP CANbus, RS-232
- Up to 60MPa range

In most measuring system used in the sea, pressure is a vital parameter. For moored instruments the pressure can be used for determining the actual depth of the instrument. For instrumentation on the seabed the pressure can be used for deriving water level. The pressure is also vital when deriving other parameters as density and speed of sound.

The Pressure Sensor 4117 is a compact yet intelligent sensor designed to be used on the AADI SEAGUARD® as well as in other measuring systems. The sensor is based on a silicon piezoresistive bridge sampled and temperature compensated by an advanced Digital Signal Processor. The sensor is housed in a rugged titanium cylinder.

Since all calibration and temperature compensation data are stored inside the sensor, the pressure is by default presented directly in engineering units without any external calculation. Raw data can be selected as additional output. Two parameters are available; Pressure and Temperature.

The SEAGUARD® and the smart sensors are interfaced by means of a reliable CANbus interface using an XML based protocol (AiCaP). The Smart sensors can be mounted directly on the top-end plate of the AADI SEAGUARD® and are automatically detected and recognized.

The output parameters from the SEAGUARD® applications are easily presented in SEAGUARD Studio.

The 10-pin receptacle in the sensor foot mates with AADI CSP (Cylindrical Sealing plug), giving access to RS-232 output. For connection to a PC the Sensor Cable 4865 can be used. It is furnished with a watertight 10-pin plug at the sensor end. An additional USB plug is used for providing power to the sensor.

The Pressure sensor can be used as stand-alone sensor with AADI Real-time Collector for Real-time data.

# Specifications for 4117

D362 - December 2009

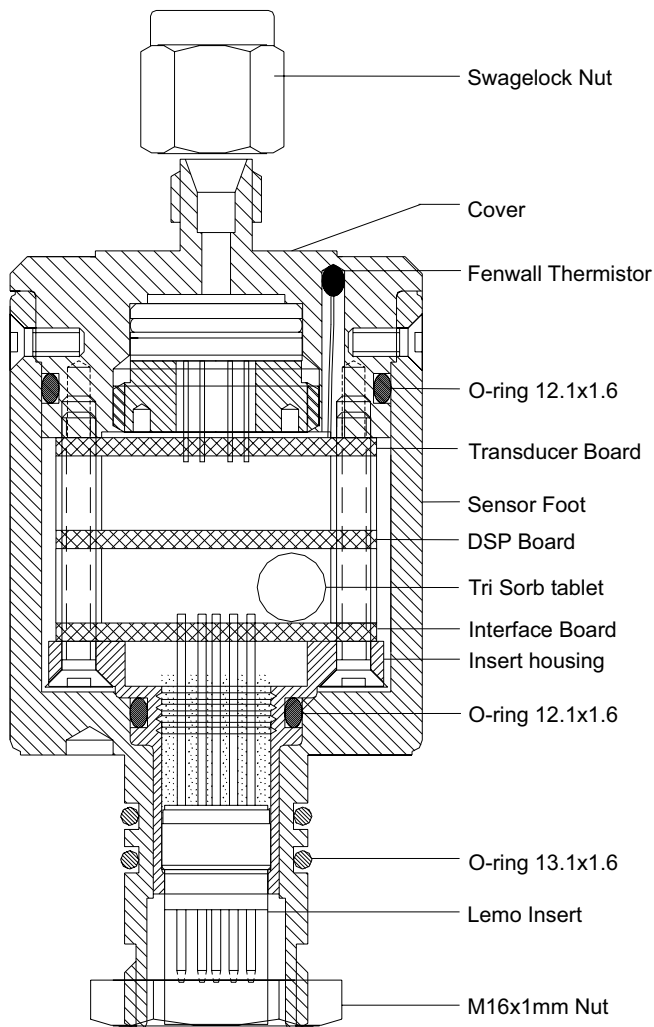

**Pressure:**  
**4117A Range:** 0 – 1000kPa (0 – 145 psia)<sup>(1),(2)</sup>  
**4117B Range:** 0 – 4000kPa (0 – 580 psia)<sup>(2)</sup>  
**4117C Range:** 0 – 10000kPa (0 – 1450 psia)<sup>(1),(2)</sup>  
**4117D Range:** 0 – 20000kPa (0 – 2900 psia)<sup>(2)</sup>  
**4117E Range:** 0 – 40000kPa (0 – 5800 psia)<sup>(1),(2)</sup>  
**4117F Range:** 0 – 60000kPa (0 – 8700 psia)<sup>(2)</sup>  
**Resolution:** <0.0001% FSO  
**Accuracy:** ±0.04% FSO

**Temperature:**  
**Range:** 0 – 36°C (32 – 96.8°F)  
**Resolution:** <0.001°C (0.0018°F)  
**Accuracy:** ±0.1°C (0.18°F)  
**Response Time (63%):** <10 seconds

**Output format:** AiCaP CANbus, ASCII RS-232<sup>(3)</sup>  
**Sampling interval:** RS-232: 1s – 255 minutes  
 AiCaP: Controlled by Seaguard  
**Supply voltage:** 6 to 14VDC

**Current drain(@ 9V):**  
**Average(RS-232):** 14mA/S + 0.25mA where S is sampling interval in seconds  
**Maximum(RS-232):** 50 mA  
**Quiescent:** 0.25 mA

**Operating temperature:** -5 – +40°C (23 – 104°F)  
**Electrical connection:** 10-pin receptacle mating plug CSP  
**Pressure connection:** Swagelok™ 1/8 inch  
**Dimensions:** OD: 36 x 86mm (OD:1.4”x3.4”)  
**Weight:** 160g (5.47oz)  
**Materials:** Titanium and Epoxy coating

**ACCESSORIES**

**included:** 840017 Swagelok plug SS-200-P  
**not included:** RS-232 Sensor Cable 4762<sup>(4)</sup>/4865<sup>(5)</sup>

*(1) Available on request*  
*(2) Pressure conversion: 1000kPa = 100m depth*  
*(3) 9600 baud, 8 data bits, 1 stop bit, no parity, Xon/Xoff Handshake*  
*(4) CSP Cable with free end for Real-time data*  
*(5) CSP Cable to PC with 9pin D-sub for Real-time data*

**PIN CONFIGURATION**

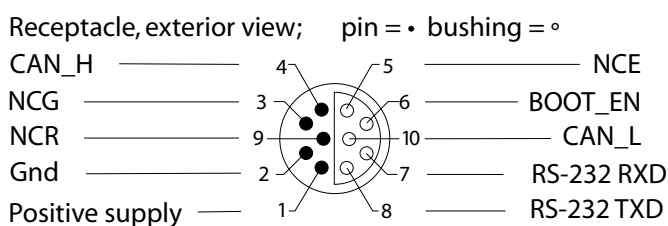

Note! If deployed at higher pressure than the range of the pressure sensor, the pressure port must be closed by use of the Swagelok plug SS-200-P (stock no. 840017).

*The above specifications are for the stand-alone sensor only, not the installation it is utilized with.*  
*Specifications subject to change without prior notice.*

Post Box 34 SLÅTTHAUG  
 5851 BERGEN, NORWAY  
 TEL. +47 55 60 48 00  
 FAX. +47 55 60 48 01

<http://www.aadi.no>  
 e-mail: [info@aadi.no](mailto:info@aadi.no)



Representative's Stamp