

HOBO® Pendant G
Acceleration Data Logger
(Part # UA-004-64)

Inside this package:

- HOBO Pendant G Acceleration Data Logger
- Mounting bracket and screw



Doc # 10872-A, MAN-UA-004
 Onset Computer Corporation

Thank you for purchasing a HOBO data logger. With proper care, it will give you years of accurate and reliable measurements.

The HOBO Pendant G Acceleration Data Logger is a waterproof, three-channel logger with 8-bit resolution and can record up to approximately 21,800 combined x-, y-, and z-axis acceleration readings or internal logger events. The logger uses a coupler and optical base station with USB interface for launching and data readout by a computer.

The logger can be used for a wide variety of experiments, demonstrations and field studies by measuring dynamic acceleration resulting from motion, shock or vibration. It can also detect static acceleration of gravity, making it possible to measure tilt, activity, and inclination.

The logger uses an internal three-axis accelerometer with a range of $\pm 3 g$ based on micro-machined silicon sensors consisting of beams that deflect with acceleration. These beams are arranged to act as a variable capacitor. As the beams move, the capacitance changes proportionately. This capacitance change is converted to voltage, filtered and measured by the logger, and displayed in the software in units of g-force.

A base station, coupler, and HOBOWare® software are required for logger operation. Visit www.onsetcomp.com for compatibility information.

Specifications

Measurement range	$\pm 3 g$; 29.4 m/s^2 (96.5 ft/s^2)
Accuracy	$\pm 0.075 g$; 0.735 m/s^2 (2.41 ft/s^2) at 25°C (77°F) $\pm 0.105 g$; 1.03 m/s^2 (3.38 ft/s^2) from -20°C to 70°C (-4°F to 158°F)
Resolution	$0.025 g$; 0.245 m/s^2 (0.8 ft/s^2)
Logging interval	1 second to 18 hours, 12 minutes, 15 seconds in Normal mode 0.01 seconds (100 Hz) to 0.99 seconds (1.01 Hz) in Fast mode
Time accuracy	± 1 minute per month at 25°C (77°F), see Plot A
Operating range	In water/ice: -20° to 50°C (-4° to 122°F) In air: -20° to 70°C (-4° to 158°F)
Water depth rating	30 m from -20° to 20°C (100 ft from -4° to 68°F), see Plot B
Battery life	1 year typical use in Normal mode; 7 days logging at 0.01 seconds (100 Hz) in Fast mode
Memory	64K bytes (approximately 21.8K combined x-, y-, and z-axis readings or events)
Materials	Polypropylene case; stainless steel screws; Buna-N o-ring
Weight	18 g (0.6 oz)
Dimensions	58 x 33 x 23 mm (2.3 x 1.3 x 0.9 inches)
CE	The CE Marking identifies this product as complying with the relevant directives in the European Union (EU).

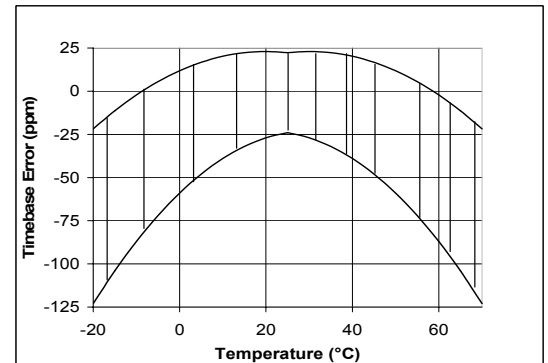

Plot A

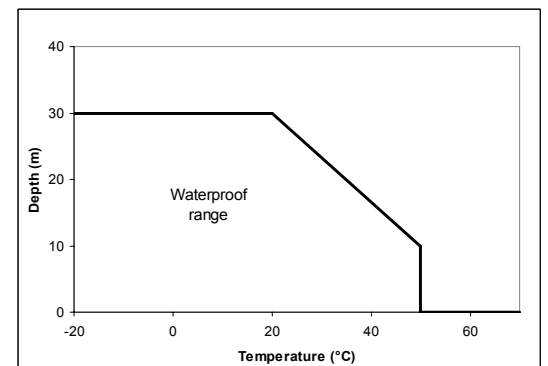

Plot B

Connecting the logger

The HOBO Pendant G logger requires HOBOWare Pro or HOBOWare Lite, and either of the following to connect to the computer:

- Pendant Optic USB Base Station & Coupler (part # BASE-U-1)

OR

- Optic USB Base Station (part # BASE-U-4) or HOBO Waterproof Shuttle (part # U-DTW-1); coupler (part # COUPLER2-A)

If possible, avoid connecting at temperatures below 0°C (32°F) or above 50°C (122°F).

1. Plug the USB connector on the base station into an available USB port on your computer.
2. Insert the logger and the base station into the coupler, as shown in the following diagrams.

For BASE-U-1, make sure that the logger is inserted in the end of the coupler that has the magnet, and that the ridges on the base station and logger are aligned with the grooves in the coupler.

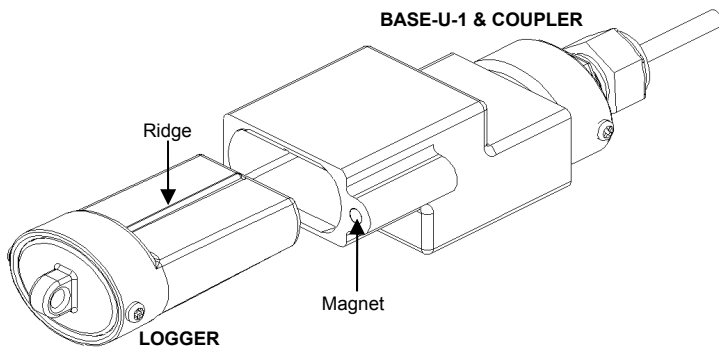

For BASE-U-4 or the HOBO Waterproof Shuttle, firmly insert the optical end of the base station into the D-shaped end of the coupler, and make sure that the ridge on the logger is aligned with the groove in the coupler.

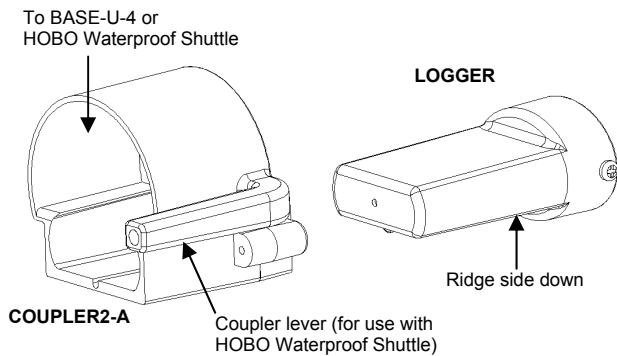

3. If you are using the HOBO Waterproof Shuttle, briefly press the coupler lever to put the shuttle into base station mode.
4. If the logger has never been connected to the computer before, it may take a few seconds for the new hardware to be detected.
5. Use the logger software to set up the alarms, launch, and read out the logger.

You can read out the logger or check its status while it continues to log (in Normal logging mode only); stop it manually with the software; or let it record data until the memory is full. Refer to the software user's guide for complete details on launching, reading out, and viewing data from the logger.

Triggered start

This logger can be configured to start at your command, using the magnet in the coupler to trigger a start. (To log in Fast mode, this is the *only* way to launch the logger.)

1. Use the logger software to launch the logger with Trigger Start selected. Remove the logger from the coupler.
2. Bring the logger and an empty coupler or strong magnet to the deployment location.

Important: Any magnet can trigger a start. This can be helpful, but it can also cause a premature start. Keep the logger away from strong magnetic fields until you are ready to begin logging.

3. When you are ready for the logger to start logging, insert the logger into the empty coupler (or place it next to a strong magnet) and remove it after three seconds. **Important: The logger will not launch if the base station is in the coupler.**
4. Verify that the logger's light is blinking at least every four seconds.

Sample and event logging

While logging in Normal mode, the logger can record two types of data: samples and internal logger events. Samples are the measurements recorded at each logging interval (for example, x-axis acceleration every minute). Events are independent occurrences triggered by a logger activity, such as Bad Battery or Host Connected. Events help you determine what was happening while the logger was logging.

Events are not logged in Fast mode.

Normal vs. Fast logging modes

When you launch the logger, you can choose between Normal mode and Fast mode. In Normal mode, the logger's fastest logging interval is once per second. Normal mode is ideal for applications involving tilt, activity, and inclination. These applications do not require information about the dynamics of the acceleration events, but rely more on the static acceleration of gravity.

Fast mode allows logging intervals between 0.01 and 0.99 seconds (100 to 1.01 Hz), making it ideal for applications involving vibration and shock. These applications are more concerned with the dynamics of the acceleration events over short periods, and would not be captured in Normal mode. **Important: Connecting the logger to the computer (or a shuttle) when logging in Fast mode will stop the logger.**

The logger's memory can store roughly 60,000 measurements. The time required to fill this memory depends on how many channels and events are being logged, as well as the logging interval. For example, if you log x-, y-, and z-axis acceleration at 100 Hz, the logger's memory will fill up in less than four minutes. An estimated duration, based on the logging interval and channels you select, is displayed on the Launch window in HOBOWare.

Operation

A light (LED) on the front of the logger confirms logger operation. The following table explains when the light blinks during logger operation.

When:	The light:
The logger is awaiting an Interval, Delayed, or Trigger Start	Blinks once every eight seconds until logging begins.
Logger is subjected to a magnetic field	Blinks once every second when the magnet is present, then (Normal mode only) blinks rapidly three times when logging begins.
The logger is logging in Normal mode	Blinks once every one to four seconds (the shorter the logging interval, the faster the light blinks); blinks when logging a sample
The logger is logging in Fast mode	Blinks once every quarter-second

Mounting the logger

The provided mounting bracket offers two orientation options for securing the logger to a rigid surface.

Secure the bracket to the object of interest, then use the mounting screw provided to attach the logger to the bracket.

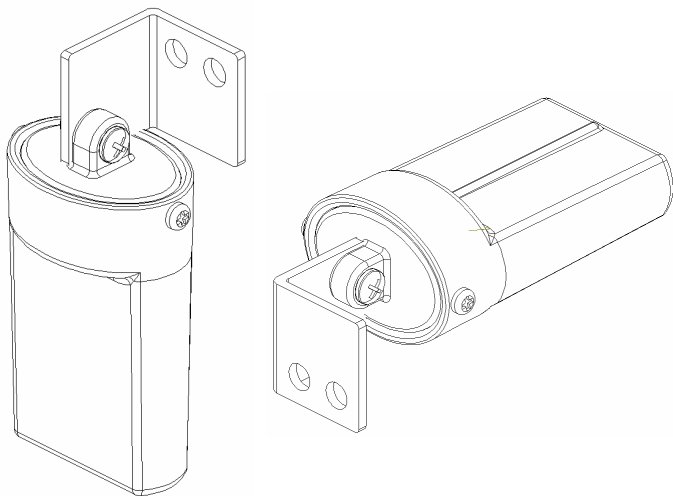

Protecting the logger

The logger can be damaged if the water depth rating is exceeded. The depth rating is approximately 30 m (100 ft) at temperatures below 20°C (68°F), but is less in warmer water. Refer to Plot B for details.

Do not store the logger in the coupler. Remove the logger from the coupler when you are not using it. When the logger is in the coupler or near a magnet, it consumes more power and will drain the battery prematurely.

Keep the logger away from magnets. Being near a magnet can cause false coupler events to be logged. It can also launch the logger prematurely if it is waiting for a trigger start.

Note! Static electricity may cause the logger to stop logging. To avoid electrostatic discharge, transport the logger in an anti-static bag, and ground yourself by touching an unpainted metal surface before handling the logger. For more information about electrostatic discharge, visit <http://www.onsetcomp.com/support/support.html>.

Periodically inspect the desiccant and dry it if it is not bright blue. The desiccant pack is located in the cap of the logger. To dry the desiccant, remove the desiccant pack from the cap and leave the pack in a warm, dry location until the bright blue color is restored. (Refer to the “Battery” section for instructions on removing and replacing the logger cap.)

Temperature range	Desiccant maintenance schedule
Less than 30°C (86°F)	Approximately once per year
30° to 40°C (86° to 104°F)	Approximately every six months
Over 40°C (104°F)	Approximately every three months

Factory calibration

The logger is factory-calibrated and does not require any additional calibration. To verify proper calibration, check the logger’s status (when it is not logging) in the HOBOWare software to check the logger’s response to gravity. When any of the axes are held horizontally, you should see a reading close to zero. When held vertically, with the arrow facing downwards, the response should be close to 1 g.

Battery

The logger requires one 3-Volt CR-2032 lithium battery. Battery life varies based on the temperature and the frequency at which the logger is recording data (the logging interval). A new battery typically lasts one year with logging intervals greater than one minute. Deployments in extremely cold or hot temperatures, or logging intervals faster than one minute, may significantly reduce battery life. Continuous logging at the fastest logging rate of 0.01 seconds (100 Hz) will deplete the battery in as little as one week.

To replace the battery:

1. Remove the two screws that secure the end cap to the case and remove the cap.
2. Examine the desiccant pack that is tucked into the cap. If the desiccant is not bright blue, put the desiccant pack in a warm, dry place until the blue color is restored.
3. Gently tap the case to loosen the circuit board and remove it from the case.

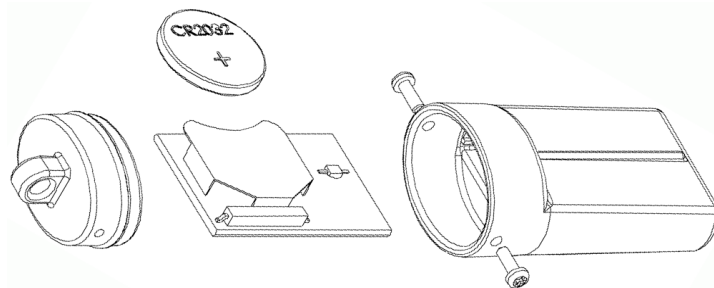

4. Carefully push the battery out of the holder with a small, nonmetallic blunt instrument.
5. Insert a new battery, positive side facing up.
6. Return the circuit board and label to the case, carefully aligning the circuit board with the grooves in the case so that the battery faces the ridged side of the case.

7. Replace the end cap, ensuring that the desiccant pack is tucked into the cap, and the o-ring is seated in the groove, not pinched or twisted. Make sure no dirt or lint is trapped on the o-ring, as this could result in a leak.
8. Re-fasten the screws. Do not over-tighten the screws.

⚠ WARNING: Do not cut open, incinerate, heat above 85°C (185°F), or recharge the lithium battery. The battery may explode if the logger is exposed to extreme heat or conditions that could damage or destroy the battery case. Do not dispose of the logger or battery in fire. Do not expose the contents of the battery to water. Dispose of the battery according to local regulations for lithium batteries.

Service and Support

As part of Onset's ongoing efforts to provide 100% customer satisfaction, our Continuing Engineering Group constantly monitors and evaluates all of our products and software. In the unlikely event any significant defect is found, Onset will notify you. If you find a defect, please e-mail us at loggerhelp@onsetcomp.com.

HOBO products are easy to use and reliable. In the unlikely event that you have a problem with this instrument, contact the company where you bought the logger: Onset or an Onset Authorized Dealer. Before calling, you can evaluate and often solve the problem if you write down the events that led to the problem (are you doing anything differently?) and if you visit the Technical Support section of the Onset web site at www.onsetcomp.com/support.html. When contacting Onset, ask for technical support and be prepared to provide the product number and serial number for the logger and software version in question. Also completely describe the problem or question. The more information you provide, the faster and more accurately we will be able to respond.

Onset Computer Corporation
470 MacArthur Blvd., Bourne, MA 02532
Mailing: PO Box 3450, Pocasset, MA 02559-3450
Phone: 1-800-LOGGERS (1-800-564-4377) or 508-759-9500
Fax: 508-759-9100
E-mail: loggerhelp@onsetcomp.com
Internet: www.onsetcomp.com

Warranty

Onset Computer Corporation (Onset) warrants to the original end-user purchaser for a period of **one year** from the date of original purchase that the HOBO® product(s) purchased will be free from defect in material and workmanship. During the warranty period Onset will, at its option, either repair or replace products that prove to be defective in material or workmanship. This warranty shall terminate and be of no further effect at the time the product is (1) damaged by extraneous cause such as fire, water, lightning, etc. or not maintained in accordance with the accompanying documentation; (2) modified; (3) improperly installed; (4) repaired by someone other than Onset; or (5) used in a manner or purpose for which the product was not intended.

THERE ARE NO WARRANTIES BEYOND THE EXPRESSED WARRANTY ABOVE. IN NO EVENT SHALL ONSET BE LIABLE FOR LOSS OF PROFITS OR INDIRECT, CONSEQUENTIAL, INCIDENTAL, SPECIAL OR OTHER SIMILAR DAMAGES ARISING OUT OF ANY BREACH OF THIS CONTRACT OR OBLIGATIONS UNDER THIS CONTRACT, INCLUDING BREACH OF WARRANTY, NEGLIGENCE, STRICT LIABILITY, OR ANY OTHER LEGAL THEORY.

Limitation of Liability. The Purchaser's sole remedy and the limit of Onset's liability for any loss whatsoever shall not exceed the Purchaser's price of the product(s). The determination of suitability of products to the specific needs of the Purchaser is solely the Purchaser's responsibility.

THERE ARE NO WARRANTIES BEYOND THE EXPRESSED WARRANTY OFFERED WITH THIS PRODUCT. EXCEPT AS SPECIFICALLY PROVIDED IN THIS DOCUMENT, THERE ARE NO OTHER WARRANTIES EXPRESS OR IMPLIED, INCLUDING

BUT NOT LIMITED TO, ANY IMPLIED WARRANTIES OF MERCHANTABILITY OR FITNESS FOR A PARTICULAR PURPOSE. NO INFORMATION OR ADVICE GIVEN BY ONSET, ITS AGENTS OR EMPLOYEES SHALL CREATE A WARRANTY OR IN ANY WAY INCREASE THE SCOPE OF THE EXPRESSED WARRANTY OFFERED WITH THIS PRODUCT.

Indemnification. Products supplied by Onset are not designed, intended, or authorized for use as components intended for surgical implant or ingestion into the body or other applications involving life-support, or for any application in which the failure of the Onset-supplied product could create or contribute to a situation where personal injury or death may occur. Products supplied by Onset are not designed, intended, or authorized for use in or with any nuclear installation or activity. Products supplied by Onset are not designed, intended, or authorized for use in any aeronautical or related application. Should any Onset-supplied product or equipment be used in any application involving surgical implant or ingestion, life-support, or where failure of the product could lead to personal injury or death, or should any Onset-supplied product or equipment be used in or with any nuclear installation or activity, or in or with any aeronautical or related application or activity, Purchaser will indemnify Onset and hold Onset harmless from any liability or damage whatsoever arising out of the use of the product and/or equipment in such manner.

Returns

Please direct all warranty claims and repair requests to place of purchase.

Before returning a failed unit directly to Onset, you must obtain a Return Merchandise Authorization (RMA) number from Onset. You must provide proof that you purchased the Onset product(s) directly from Onset (purchase order number or Onset invoice number). Onset will issue an RMA number that is valid for 30 days. You must ship the product(s), properly packaged against further damage, to Onset (at your expense) with the RMA number marked clearly on the outside of the package. Onset is not responsible for any package that is returned without a valid RMA number or for the loss of the package by any shipping company. Loggers must be clean before they are sent back to Onset or they may be returned to you.

Repair Policy

Products that are returned after the warranty period or are damaged by the customer as specified in the warranty provisions can be returned to Onset with a valid RMA number for evaluation.

ASAP Repair Policy. For an additional charge, Onset will expedite the repair of a returned product.

Data-back™ Service. HOBO data loggers store data in nonvolatile EEPROM memory. Onset will, if possible, recover your data.

Tune Up Service. Onset will examine and retest any HOBO data logger.

© 2006 Onset Computer Corporation. All rights reserved.

Part #: MAN-UA-004, Doc #: 10872-A, Patent #: 6,826,664

Onset, HOBO, and HOBOware are registered trademarks of Onset Computer Corporation for its data loggers and data logger configuration/interface software. Other products and brand names may be trademarks or registered trademarks of their respective owners.